

OIL-FREE UNIVERSAL GUIDE BUSHINGS

— STRAIGHT BRONZE TYPE —

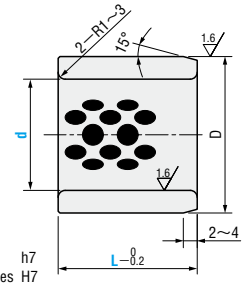

GGBP



• Slide direction

☞

☒ Copper alloy
Special solid lubricant (embedded)

- Matching shaft tolerance
- Recommended machining tolerance for holes H7

d	D	Catalog No.		L
		Type	d	
20	30	+0.105 +0.072	20	20 25 30
25	35		25	20 30 40
30	40		30	25 30 40
30	42	+0.144 +0.105	30A	25 30 40
32	42		32	30 40
32	45		32A	30 40
35	45		35	30 40 50
35	48		35A	30 40 50
40	50		40	30 40 50
40	55		40A	30 40 50
45	55		45	40 50
45	60		45A	40 50
50	60		50	40 50 60
50	65	50A	40 50 60	
55	70	+0.190 +0.144	55	50 60
60	75		60	50 60 80
60	80		60A	50 60 80
65	80		65	60 80
65	85		65A	60 80
70	85		70	60 80
70	90		70A	60 80
75	90		75	60 80
75	95		75A	60 80
80	95		80	80 100
80	100	80A	80 100	
85	100	85	80 100	
85	105	85A	80 100	
90	110	+0.242 +0.188	90	80 100
90	115		90A	80 100
100	120		100	80 100 120
160	125		100A	80 100 120

☎ Order

Catalog No. — L

GGBP60 — 50

GGBP60A — 50

☚ Days to Ship **Quotation**

☒ Price **Quotation**

OIL-FREE UNIVERSAL GUIDE BUSHINGS

— FLANGE TYPE —



GGBF

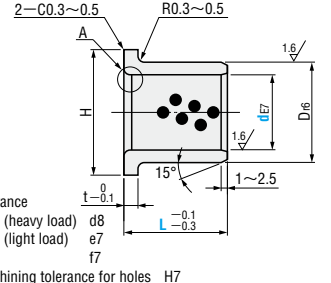

• Slide direction

☞

☒ Copper alloy
Special solid lubricant (embedded)

- Matching shaft tolerance
- For general purpose (heavy load) d8
- For general purpose (light load) e7
- For high precision f7
- Recommended machining tolerance for holes H7

de7	D/6	H	t	Catalog No.		L
				Type	d	
8	12	+0.034 +0.023	20	GGBF	8 10 15	
10	14		22		10 10 12 15 17 20	
12	18	25	12 15 20 25 30			
13	19	26	13 15 20			
14	20	27	14 15 20 25			
15	21	28	15 15 20 25 30			
16	22	29	16 15 18 20 23 25 30 35 40			
18	24	32	18 20 30			
20	30	40	20 15 20 25 30 35 40			
25	35	45	25 15 20 25 30 35 40 50			
30	40	50	30 20 25 30 35 40 50			
35	45	60	35 20 25 30 35 40 50			
40	50	65	40 20 25 30 35 40 50			
45	55	70	45 30 35 40 50 60			
50	60	75	50 30 35 40 50 60			
55	65	80	55 40 60			
60	75	90	60 40 50 80			
70	85	105	70 50 80			
80	100	120	80 60 80 100			
90	110	130	90 60 80			
100	120	150	100 80 100			
120	140	170	120 80 100			

☎ Order

Catalog No. — L

GGBF60 — 50

☚ Days to Ship **Quotation**

☒ Price **Quotation**