

ENGRAVING PUNCHES

DIE CHECK BUTTONS / SHIMS

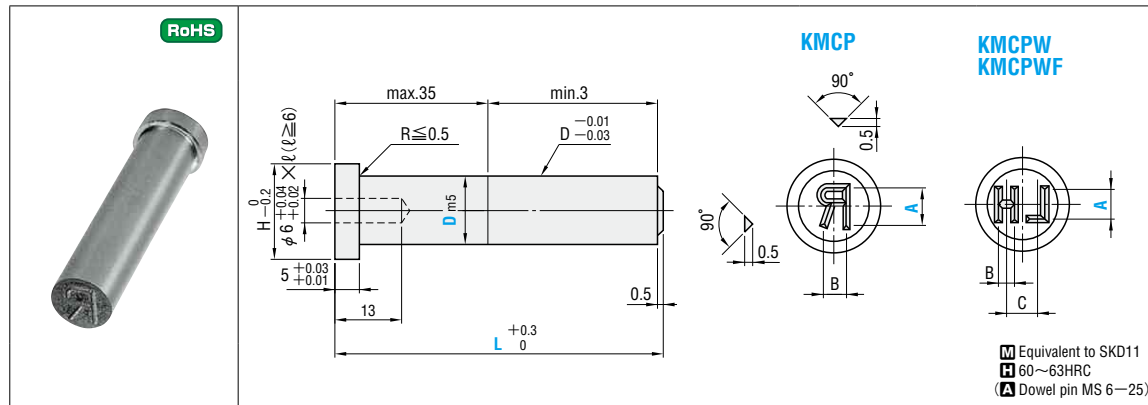

H	B	C	Catalog No.		0.1mm increments L	A	Characters CHR	Base unit price 1~9 pieces
			Type	D				
13	3.3	-	KMCP (1 character)	10	30.0~120.0	5	0 1 2 3 4 5 6 7 8 9 A B C D E F G H I J K L M N O P Q R S T U V W X Y Z	Quotation
	4			10		6		
	5.3			13		8		
	6.5			16		10		
16	3.3	5	KMCPW (2 characters)	10	30.0~120.0	4	RH LH FR FL RR RL	Quotation
				13		5		
				16		6		
				20		8		
19	4	6	KMCPWF (Any 2 characters)	10	30.0~120.0	4	0 1 2 3 4 5 6 7 8 9 A B C D E F G H I J K L M N O P Q R S T U V W X Y Z	Quotation
				13		5		
				16		6		
				20		8		
23	5.3	8	KMCPW	20	30.0~120.0	8	RH LH FR FL RR RL	Quotation
				25		10		
28	6.5	10	KMCPWF	10	30.0~120.0	4	0 1 2 3 4 5 6 7 8 9 A B C D E F G H I J K L M N O P Q R S T U V W X Y Z	Quotation
				13		5		
13	2.5	3.5	KMCPW	10	30.0~120.0	4	RH LH FR FL RR RL	Quotation
				13		5		
16	3.3	5	KMCPWF	10	30.0~120.0	4	0 1 2 3 4 5 6 7 8 9 A B C D E F G H I J K L M N O P Q R S T U V W X Y Z	Quotation
				13		5		
19	4	6	KMCPW	10	30.0~120.0	4	RH LH FR FL RR RL	Quotation
				13		5		
23	5.3	8	KMCPWF	10	30.0~120.0	4	0 1 2 3 4 5 6 7 8 9 A B C D E F G H I J K L M N O P Q R S T U V W X Y Z	Quotation
				13		5		
28	6.5	10	KMCPW	10	30.0~120.0	4	RH LH FR FL RR RL	Quotation
				13		5		

• KMCPW
RH...RIGHT HAND FR...FRONT RIGHT RR...REAR RIGHT
LH...LEFT HAND FL...FRONT LEFT RL...REAR LEFT

Order	Catalog No.	L	A	CHR
	KMCP 13	110.0	A8	G
	KMCPWF 16	110.0	A6	AB

Days to Ship **Quotation**

Price **Quotation**

Alterations	Catalog No.	L	A	CHR	(KC-SRC)
	KMCP 10	80.0	A5	R	KC90

Alteration	Code	Spec.	1Code
	KC	Addition of key flat to head 90° increments KC0 KC90 KC180 KC270	Quotation

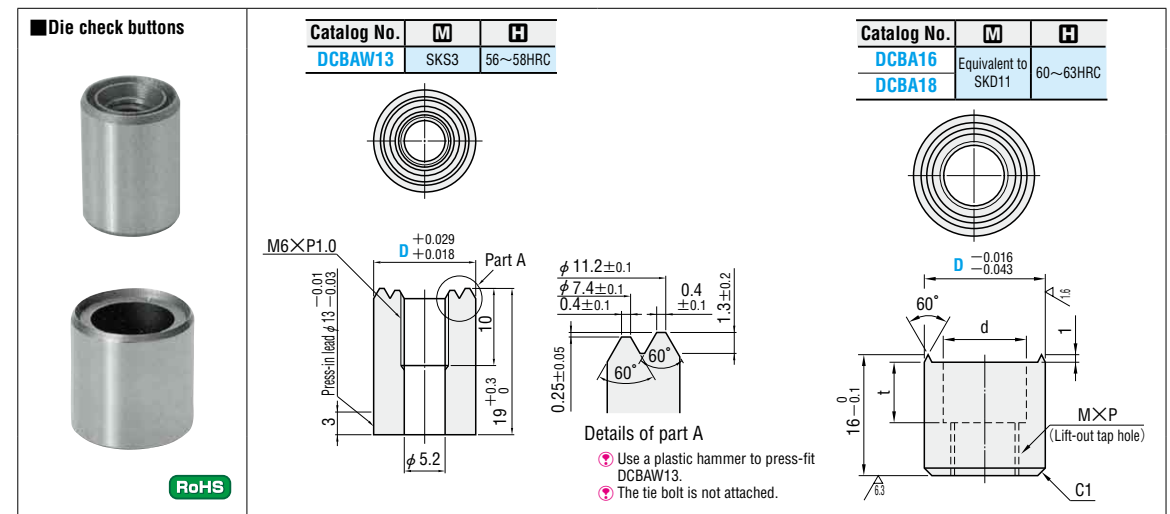

d	Tie bolt size	M×P	t	Catalog No.		Base unit price 1~4 pieces
				Type	D	
-	-	M 6×P1.0	-	DCBAW	13	Quotation
11	CB6-20	M 8×P1.25	8	DCBA	16	Quotation
13.5	CB8-25	M10×P1.5	10	DCBA	18	Quotation

Order **Catalog No.**
DCBA 16

Days to Ship **Quotation**

Price **Quotation**

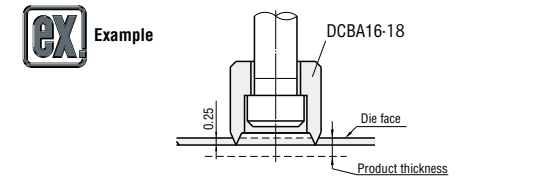

- Mounting position
 - Choose a position where the mark will not have any effect on the product.
 - Select a location that is as flat as possible for the punch to contact, and install the punch perpendicular to that surface.
- Fasten the punch using a bolt. The punch tip should protrude 0.25mm from the mounting surface. (Depth of character engraved in product: 0.25mm)

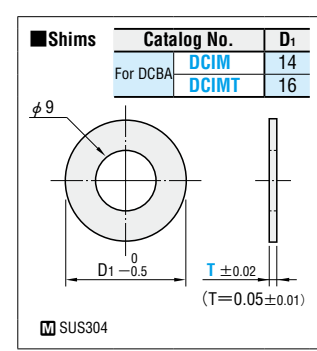

Catalog No.	T	Base unit price 1~4 pieces	
		DCIM	DCIMT
DCIM DCIMT	0.05		
	0.1		
	0.2	Quotation	
	0.3		
	1.0		

Order **Catalog No.**
DCIM 0.05

Days to Ship **Quotation**

Price **Quotation**