

NEW

PIPE TYPE JIG FOR SODICK INJECTION MOLDING MACHINE

PIPE TYPE JIG

DEDICATED FOR SODICK INJECTION MOLDING MACHINE



■ **Application** Use to remove the plasticizing cylinders and etc. of Injection Molding Machine manufactured by Sodick.

RoHS 10

M-SJP-20A

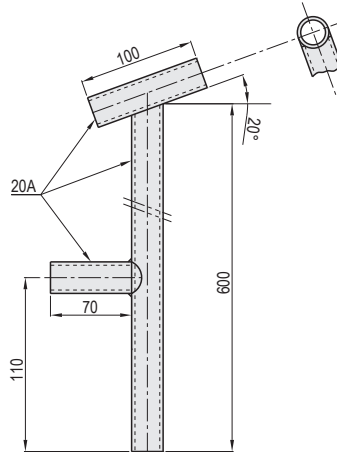

Standardized under the supervision of Sodick Co., Ltd.

M Material Steel pipe STPG370 or equivalent
S Surface treatment Black oxide

Part Number	Unit Price
	1~3 pcs
M-SJP-20A	Quotation



Order

Part Number

M-SJP-20A



Days to Ship

Quotation



Price

Quotation

■ Applications

- If the nut cannot be loosened using the extend socket, insert the pipe type jig into the handle and turn the jig.
- ⚠ When performing maintenance on the molding machine, check the Sodick's instruction manual and implement appropriate safety measures against burns and electric shock, etc.
- ⚠ Perform the necessary preparations for removing the plasticizing cylinder, such as removing the plasticizing motor and non-return unit.
- ⚠ The jig can also be used for various other applications, but be especially careful during use to prevent jigs and tools from slipping off or being damaged.
- ⚠ Extend socket **P.69**

INJECTION MOLDING
MACHINE RELATED PRODUCTS