

# BLOCK AIR NIPPERS SQUARE AIR NIPPERS

Blade sold separately

shows in red

\*Some products may not be available, please contact your local MISUMI Sales Office for more information.

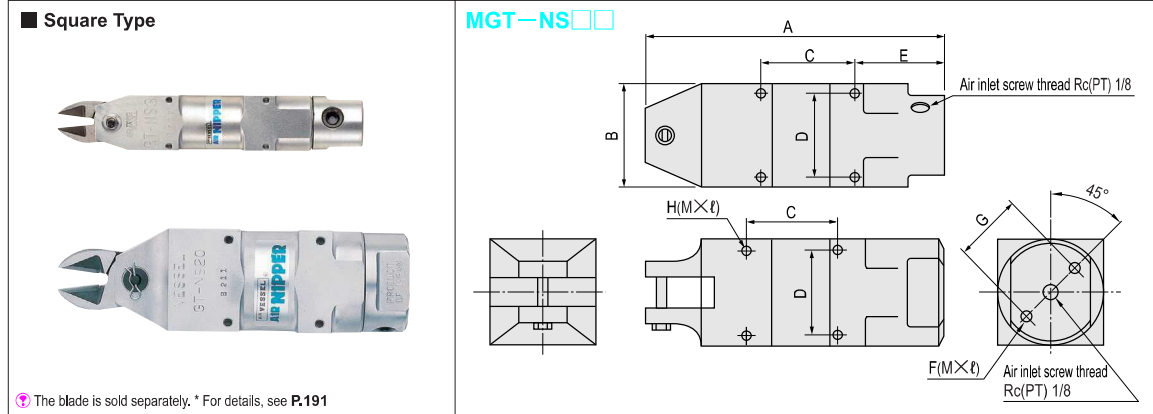

The blade is sold separately. \* For details, see P.191

Cutting capacity $\phi$ (mm)				Air consumption (cm <sup>3</sup> /time)	Weight (g)	Part dimensions (mm)								Part Number	Unit Price 1~9 pcs
Soft resin	Hard resin	Copper wire	Iron wire			A	B	C	D	E	F	G	H		
2.0	-	1.0	0.5	45	95	110	23	40	19	40	M3x8	17	M3x3.5	MGT-NS3	Quotation
2.0	-	1.0	0.5	64	135	94	30	30	24	34	M4x10	20	M3x5	MGT-NS5	
3.0	2.0	1.6	1.0	116	215	113	36	30	28	18	M4x10	24	M4x5.5	MGT-NS7	
4.0	2.6	1.8	1.2	116	215	113	36	30	28	38	M4x10	24	M4x5.5	MGT-NS10L	
7.0	5.0	2.6	2.0	230	370	129	45	40	36	19	M5x12	30	M4x7	MGT-NS20	
10.0	6.5	3.3	2.8	584	685	170	56	60	46	20	M6x12	40	M5x10	MGT-NS30	
7.0	5.0	2.6	2.0	230	455	129	45	40	36	230	M5x12	30	M4x7	MGT-NS20H-1	

- Operating air pressure MGT-NS3/5/7: 0.4~0.5 MPa
- Operating air pressure MGT-NS10L/20/30/20H-1: 0.5~0.6 MPa
- Air inlet screw thread diameter Rc(PT) 1/8 · Applicable air hose inner diameter: 5 mm

For quantities not displayed here, refer to our MISUMI website for more information.



Order

Part Number  
MGT-NS3



Days to Ship

Quotation



Price

Quotation