



NEW

LAST-MINUTE NUT / ANGLE BRACKET FOR PROFILES

LAST MINUTE NUT / ANGLE BRACKET FOR PROFILES (WITH T-NUTS)

■ **Last Minute Nut** **MPTN—M5R**

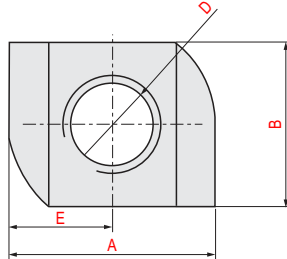
M Material	Alloy steel	S Surface treatment	Plating process (Galvanizing)
-------------------	-------------	----------------------------	-------------------------------

Part Number	A	B	C	D	E	Weight (g)
MPTN—M5R	10.6	8.2	3.6	M5	5.3	2

 **Order**
 Part Number **MPTN—M5R**
 P **Price**
 Quotation

 **Days to Ship**
 Quotation

■ **Angle Bracket for Profiles (with T-Nuts)** **MSMBJ**

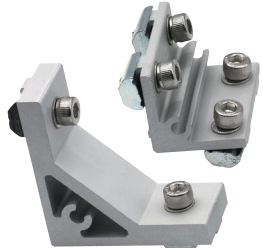
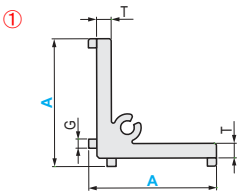
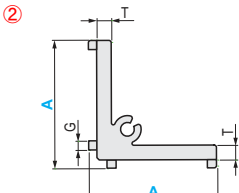
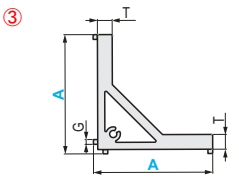





M Material	Aluminum product	S Surface treatment	Anodizing
-------------------	------------------	----------------------------	-----------

Ⓢ The surface is anodized, and the color of the actual product may vary from the product picture.

Part Number	A	B	C	D	E	F	G	T	Weight (g)	Fixing hole type	Applicable extruded profiles	Drawing no.
MSMBJ	28	18	—	5.2	9	6	2	3.2	10	Single hole	4PACK—MPEP 2—1000	①
	28	40	25	5.2	7.5	6	2	3.2	22	Double hole	4PACK—MPEP 3—1000	②
	50	22	—	6.2	11	6	2	6.2	38	Single hole	4PACK—MPEP 4—1000	③

 **Order**
 Part Number — A — B
MSMBJ — 28 — 18
 ex **Example**

 **Days to Ship**
 Quotation

P **Price**
 Quotation

