

ROUND AIR NIPPERS

Blade sold separately

shows in red

*Some products may not be available, please contact your local MISUMI Sales Office for more information.

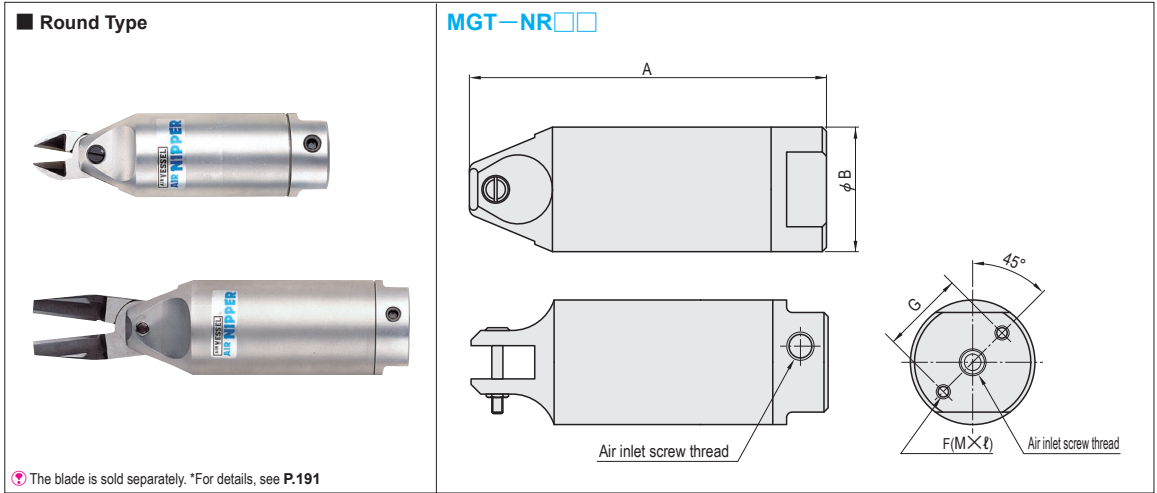

ⓘ The blade is sold separately. *For details, see P.191

Cutting capacity φ (mm)				Air consumption (cm ³ /time)	Weight (g)	Part dimensions (mm)				Hose coupling	Part Number	Unit Price 1-9 pcs
Soft resin	Hard resin	Copper wire	Iron wire			A	B	G	F			
2.0	-	1.0	0.5	45	70	110	23	17	M3×8	Rc (PT) 1/8	MGT-NR3	Quotation
2.0	-	1.0	0.5	64	110	94	30	20	M4×10		MGT-NR5	
3.0	2.0	1.6	1.0	116	150	113	34	22	M4×10		MGT-NR7	
4.0	2.6	1.8	1.2	116	215	113	36	24	M4×10		MGT-NR10L	
7.0	5.0	2.6	2.0	230	280	129	45	30	M5×12		MGT-NR20	
10.0	6.5	3.3	2.8	584	505	165	56	40	M6×12		MGT-NR30	
12.0	6.5	5.5	4.5	1170	1190	222	75	50	M8×12		Rc (PT) 1/4	

- Operating air pressure MGT-NR3/5/7: 0.4-0.5 MPa
- Operating air pressure MGT-NR10L/20/30/50: 0.5-0.6 MPa
- Applicable air hose inner diameter: 5 mm

ⓘ For quantities not displayed here, refer to our MISUMI website for more information.



Order

Part Number
MGT-NR3



Days to Ship

Quotation



Price

Quotation