

LEADER PINS FOR MIDDLE • LARGE MOLD

—L · N · B DIMENSION DESIGNATION · SHAFT DIAMETER TOLERANCE SELECTION TYPE—

ASSIST PINS FOR LEADER PIN

ⓘ Non JIS material definition is listed on P.1351 - 1352



GPX
GPP

Type	D	D(h6)	D1(f6)
GPX	40	0	-0.025
	50	-0.016	-0.041
	60	0	-0.030
	80	-0.019	-0.049
GPP	40	±0.015	-0.050
	50		-0.075
	60		-0.060
	80		-0.090

Ⓜ S50C Ⓜ 58HRC~ (Induction hardening)



GAP

Type	D	D	D1(e7)
GAP	40	±0.015	-0.050
	50		-0.075
	60		-0.060
	80		-0.090

Ⓜ S45C

A	Part Number		L		1mm increments		U/Price
	Type	D	5mm increments	N	B	1~9	
10	GPX GPP	40	100~145	N=0 or 5 ≤ N ≤ 140	B=0 or 5 ≤ B ≤ 200	Quotation	
			150~195				
			200~240				
			245~300				
			305~360				
			100~145				
		150~195					
		200~240					
		245~300					
		305~360					
		365~400					
		20	GPX GPP	60			
200~240							
245~300							
305~360							
365~400							
80	GPX GPP			80	150~195	N=0 or 5 ≤ N ≤ 200	B=0 or 5 ≤ B ≤ 200
		200~240					
		245~300					

R	ℓ	E	d	F	M (Coarse thread)	Part Number	D	L	U/Price
						Type		5mm increments	1~9
5	40	10	28	25	M24	GAP	40	60~100	Quotation
	85							105~150	
	135							155~200	
	55							80~150	
	130							155~200	
8	180	12	35	30	M30		50	205~250	
	70							100~150	
	125							155~200	
	175							205~250	
10	85	15	40	40	M36		80	120~150	
	120					155~200			
	170					205~250			
	220					255~300			

ⓘ Designate N=0 when no press-fit section is required

Order Part Number — L — N — B Price **Quotation**

Days to Ship **Quotation**

Alterations Part Number — L — N — B — (YC · GA) Alteration details P.879

GPX40 — 250 — N100 — B50 — YC

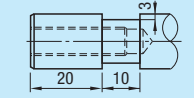
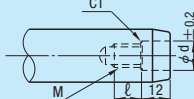
Alterations	Code	Spec.	1Code
	YC	Adds a stopper groove. Use this alteration when a tap cannot be used.	Quotation
	GA	Adds a tap to attach a leader assist pin. ⓘ Adds a tap to attach a leader assist pin (GAP). ※M: Coarse thread	

Order Part Number — L Price **Quotation**

Days to Ship **Quotation**

Example ■ Makes it possible to extend the leader pin length. (Add GA alteration to the leader pin.)
■ Available also for D40 or larger of GPHL/GPJL/GPSL.

