

OIL-FREE SLIDE PLATES

—COPPER ALLOY 10mm • 2-BOLT TYPE/4-BOLT TYPE—

OIL-FREE SLIDE PLATES / COMPACT OIL-FREE SLIDE PLATES

—SKS3 (53~56HRC) 10mm TYPE— —COPPER ALLOY 10mm TYPE—

☉ Non JIS material definition is listed on P.1351 - 1352

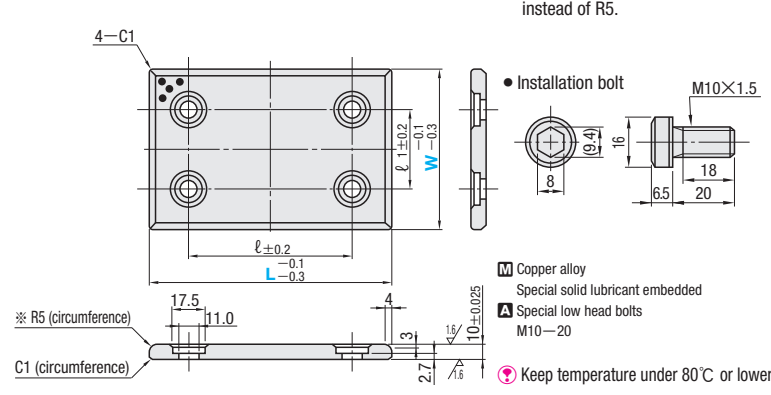
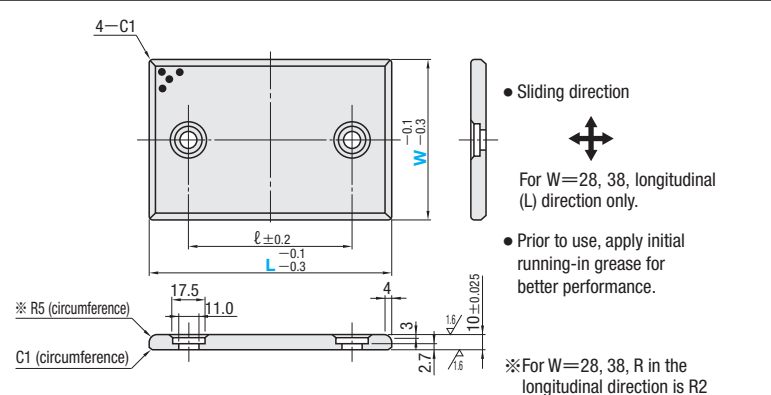

ℓ	Part Number	W	L	U/Price 1~19
45	2-bolt type STW	28	75	Quotation
50			100	
75			125	
100			150	
45			75	
50		100		
75		125		
100		150		
45		48	75	
50			100	
75			125	
100			150	
150			200	
45		58	75	
50			100	
100	150			
150	200			
200	250			
25	75	75		
50		100		
75		125		
100		150		
150		200		
50	100	100		
75		125		
100		150		
150		200		
200		250		
100	125	150		
150		200		
200		250		
100		150		
150		200		
150	150	150		
150		200		
150		200		

ℓ	ℓ ₁	Part Number	W	L	U/Price 1~19
50	50	4-bolt type STW	100	100	Quotation
75				125	
100				150	
150				200	
200				250	
100	50	125	150	150	
150				200	
200				250	
100				150	
150				200	
150	100	150	200	150	
150				200	
150				200	

Order Part Number W - L
STW 75 - 100
STWT 100 - 200

Days to Ship Quotation

Price Quotation

* ℓ dimension of STW75-75 is 25.
Pitch (ℓ) between bolts is determined which is widely taken in press dies for cars.

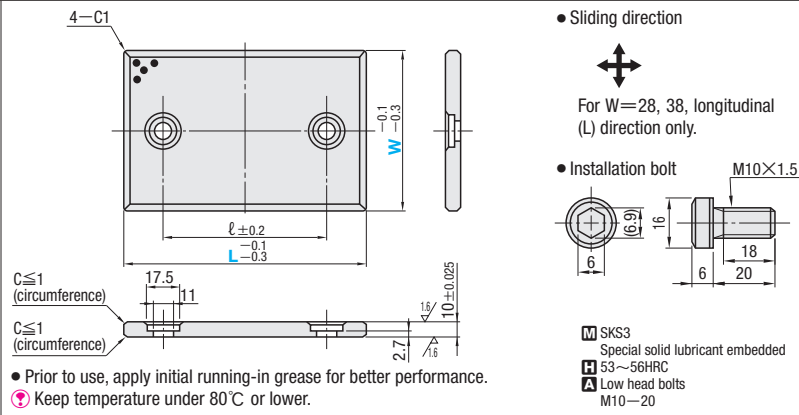

ℓ	Part Number	W	L	U/Price 1~19
45	STWSZ	28	75	Quotation
50			100	
100			150	
45			75	
50			100	
45		48	75	
50			100	
100			150	
45			75	
50			100	
45		58	75	
50			100	
100			150	
45			75	
50			100	
100	150			

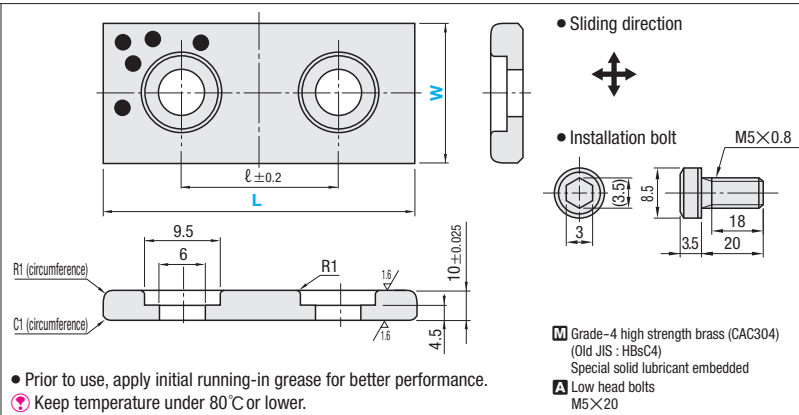

ℓ	Part Number	W	L	U/Price 1~19
14	STS	15	30	Quotation
20			40	
30			50	
50			75	
14			18	
20		40		
30		50		
50		75		
14		22		
20			40	
30			50	
50			75	
50			75	

Order Part Number W - L
STWSZ 38 - 100
STS 18 - 50

Days to Ship Quotation

Price Quotation