

# Flat Bar Mounting Plate, Bracket

## Center Symmetrical Type



Part Number Type	Material Symbol	Material	Surface Treatment
HRCZA	SS	SS400D	-
HRMZA	SSB		Black Oxide
HRMCD	SSM		Electroless Nickel Plating
	SU	SUS304D	-

(Common Dimension)

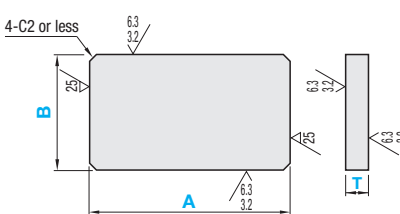

4-C2 or less

Ⓢ CO.2 to CO.5, unless otherwise specified.  
Ⓢ For other accuracy references, see P.1833

**HRCZA** 25 (Hole Machining)

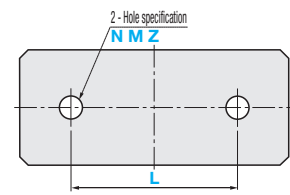

2 - Hole specification  
NMZ  
L

**HRMZA** 25 (Hole Machining)

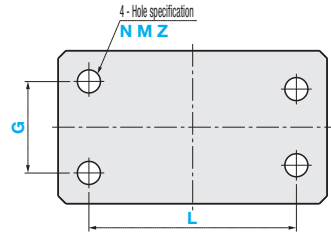

4 - Hole specification  
NMZ  
L  
G

**HRMCD** 25 (Hole Machining)

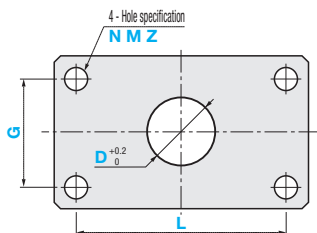

4 - Hole specification  
NMZ  
L  
G  
D<sup>+0.2</sup><sub>0</sub>

**Hole Type Selection Chart**

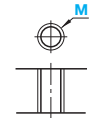
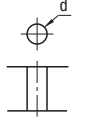
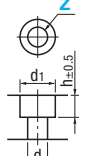
Hole Type	Tapped Holes	Bolt Hole	Counterbored Holes					
Code	M	N	Z					
Shape Diagram								
Machining Specifications	Effective tap length Max. Mx2 Ⓢ When T≥Mx3, tap pilot might not go through.							
	Screw Nominal Size							
	Dimensions							
	3	4	5	6	8	10	12	
	d, h	3.5	4.5	5.5	6.5	9	11	14
	d1	6.5	8	9.5	11	14	18	20

**Machining Limits**  
There are machining limits for thickness between holes, and between hole and edge. (Ex. "b" on the right diagram)  
For limit values, see P.1833.

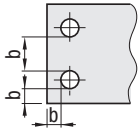

Part Number Type	Material Symbol	1mm Increment	B	T	L	G	Hole Specification		0.5mm Increment
		A					Code	Nominal Dia.	D
HRCZA HRMZA HRMCD	SS SSB SSM	30~150	16 22 25 32 38 50 60 75 100 125	6 9 10 12 16 19	0.1mm Increment		N M Z	3 4 5 6 8 10 12	3~30
	SU		15 20 25 32 38 50 65 100 125						
Ⓢ For SS( ) with B=16, T19 is not selectable. Ⓢ For SU with B specified as 15, T10 ~ 19 are not selectable. Ⓢ For SS( ) with B specified as 125, T10 is not selectable. Ⓢ For SU with B=20, T19 is not selectable.									

**Ordering Example**

Part Number: A - B - T - L - G - Hole Specification Code, Nominal Value - D

HRCZA - SSB - A80 - B60 - T6 - L60 - M6  
 HRMZA - SSB - A80 - B60 - T6 - L60 - G40 - M6  
 HRMCD - SSB - A80 - B60 - T6 - L60 - G40 - M6 - D20

A	B	T	Unit Price													
			HRCZA				HRMZA				HRMCD					
			SS	SSB	SSM	SU	SS	SSB	SSM	SU	SS	SSB	SSM	SU		
30-50	15-32	6														
		9, 10														
		12														
	38-65	6														
		9, 10														
		12														
	75-100	6														
		9, 10														
		12														
	125	6														
		9, 10														
		12														
51-100	15-32	6														
		9, 10														
		12														
	38-65	6														
		9, 10														
		12														
	75-100	6														
		9, 10														
		12														
	125	6														
		9, 10														
		12														
101-150	15-32	6														
		9, 10														
		12														
	38-65	6														
		9, 10														
		12														
	75-100	6														
		9, 10														
		12														
	125	6														
		9, 10														
		12														

Alterations

Part Number: A - B - T - L - G - Code, Nominal Value - D (DC) - (CC)

Type - Material Symbol: HRCZA - SSB - A80 - B60 - T6 - L60 - M6 - CC5

Alteration	Corner cut change	Center Hole Change to H7
	4-CC	DCH7
Code	CC	DC
Spec.	Changes corner cuts. CC = 1mm Increment 1 ≤ CC ≤ 50 Ordering Code Add CC at the end of the Part Number designation. (Ex.) ~ -CC10	Center hole D is changed to a precision hole (H7). DC = 1mm Increment 3 ≤ DC ≤ 30 HRMCD applicable only Ordering Code Specify by replacing dim. D with DC. (Ex.) ~ -DC30

**EX Example**

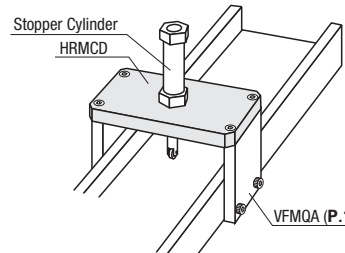

Stopper Cylinder  
HRMCD

VFMQA (P.1849)