

Rails for Switches and Sensors

L Configurable, Hole Position Fixed (Shape A, B and C)

Rails for Switches and Sensors

L Configurable, Hole Position Configurable Type (Shape B and C)

■ **Features:** Rails for Sensors with L Configurable and Hole Position Fixed. More economical than Hole Position Configurable Type. Bar Nuts P2083

Material	Surface Treatment	Part Number		
		Shape A	Shape B	Shape C
A6063S-T5	Clear Anodize	SENAF	SENBFB	SENCF

No anodizing on the tip and inner surface.
 Burrs remain on the I.D. of the mounting holes.
 No hole machining specification is required for this product.

(Shape A) SENAF: N₁ (Through Hole), L-10, L₋₁⁰
 (Shape B) SENBFB: N₂ (Through Hole), L-10, L₋₁⁰
 (Shape C) SENCF: N₂ (Through Hole), L-10, L₋₁⁰

RoHS 10

Bar Nuts P2083

Material	Surface Treatment	Part Number	
		Shape B	Shape C
A6063S-T5	Clear Anodize	SENB□□H	SENC□□H
	Black Anodize	SENB□□H	SENC□□H

No anodizing on the tip and inner surface.

(Shape B) SENB□□H, SENB□□H: N (Through Hole), L-10, L₋₁⁰
 (Shape C) SENC□□H, SENC□□H: N (Through Hole), L-10, L₋₁⁰

RoHS 10

■ **L Configurable, Hole Position Fixed** No. indicates the applicable nut size. Bar Nuts P2083

Part Number	L 1mm Increment	N	N ₁	N ₂	A	B	C	D	E	d	e	Unit Price					
												SENAF		SENBFB, SENCF			
Type	No.											L50-100	L101-200	L50-100	L101-200		
(Shape A) SENAF	3	50~200	3.5	6.5	3.5	3.4	5.7	3.0	9	6.0	1.5						
(Shape B) SENBFB	4				4.5	4.5	7.2	4.0	11	8.0	2.0						
(Shape C) SENCF	5				5.5	5.5	8.2	5.5	12	9.5	3						

■ **L Configurable, Hole Position Configurable** Please specify the mounting hole pitch as N+1.5mm or more. No. indicates the applicable nut size. Bar Nuts P2083

Part Number	L 1mm Increment	V W X Y Z 1mm Increment	N 0.5mm Increment	A	B	C	D	E	d	e	
											Type
(Shape B) SENB, SENBB	2'	50~600	5~595	3.5~5.5	2.4	4.2	2.5	7.5	5.5	1.5	2
	3	50~1200	5~1195		3.4	5.7	3.0	9	6.0		
(Shape C) SENC, SENCB	4						4.5	7.2	4.0	11	8.0
	5			5.5	8.2	5.5	12	9.5			

Ordering Example
 Part Number - L
 SENAF3 - 100
 SENCF5 - 150

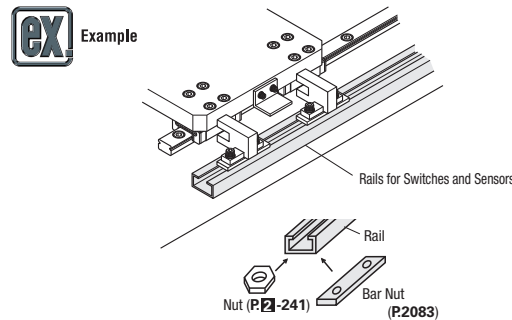

* No. 2 is available for SENC (Shape C, Clear Anodize) only. When N is not specified, N=3.5 for No. 2 or 3, N=4.5 for No. 4 and N=5.5 for No. 5.

Ordering Example
 Part Number - L - V - W - X - Y - Z - N
 SENC 3 3H - 100 - V10 - W70 - X82 - N4.0
 SENC 3 4H - 658 - V10 - W300 - X350 - Y648 - N4.5
 SENC 3 5H - 1100 - V10 - W300 - X540 - Y648 - Z1090 - N5.0

No.	Body Price (Clear Anodize)							Body Price (Black Anodize)						
	L50-100	L101-200	L201-400	L401-600	L601-800	L801-1000	L1001-1200	L50-100	L101-200	L201-400	L401-600	L601-800	L801-1000	L1001-1200
2														
3														
4														
5														

Hole Machining Charge
 H (Number of Holes) SENB, SENBB, SENC, SENCB Through Hole
 2H 200
 3H 300
 4H 400
 5H 500

(Ex.) Part Number - L - V - W - N >>>
 SENC32H - 200 - V10 - W70 - N4.5
 (Unit Price in the Table) + (Hole Machining Charge) = Unit Price for Through Hole Type

Unit Price = Body Price in the Table + Hole Machining Charge