

Slot Pins for Inspection Components

Diamond Tapered - Diamond Fixed

Slot Pins for Inspection Components

Diamond Tapered - Diamond Configurable

Features: Diamond-shaped Tapered Inspection Pins to determine the diamond shaped workpiece location. For compatible bushings, see ① Round Tip (P1841~1845) and ② D-Shape Tip (P1849).

Diamond Shape Fixed
D-Shape Tip, Large Head

| Material | Hardness | ① Round Tip | | | | ② D-Shape Tip | | | | S | g6 |
|---------------------------|----------|-------------|-----------|---------|----------|--------------------------------------|--------------------------------------|--------------------------------------|--------------------------------------|-------------|------------------|
| | | Type | | Type | | Type | | Type | | | |
| S45C Equivalent | - | KJPDTKM | KJPGDTKM | KJPDTK | KJPGDTK | S _{0.02} /F _{0.05} | S _{0.02} /F _{0.05} | S _{0.02} /F _{0.05} | S _{0.02} /F _{0.05} | 3.00 | -0.002 -0.008 |
| S45C Equivalent | 45HRC~ | KJPDTKMH | KJPGDTKMH | KJPDTKH | KJPGDTKH | - | - | - | - | 3.01~ 6.00 | -0.004 -0.012 |
| SUS304 | - | KJPDTKMS | KJPGDTKMS | KJPDTKS | KJPGDTKS | - | - | - | - | 6.01~10.00 | -0.005 -0.014 |
| SUS440C or 13Cr stainless | 45~50HRC | KJPDTKMC | KJPGDTKMC | KJPDTKC | KJPGDTKC | - | - | - | - | 10.01~18.00 | -0.008 -0.017 |
| | | | | | | | | | | 18.01~29.00 | -0.007 -0.020 |

Round Tip, Small Head

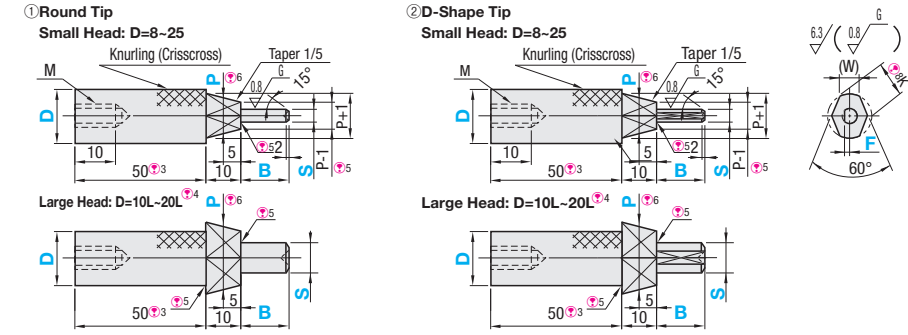

① Large Head Type (D=10L~20L) is available for S45C only. ② For electrolless nickel plating, specify the alteration MN. ③ For shorter handle length, specify the alteration ZC. ④ Dimensions not specified are the same as Small Head Type. ⑤ There is a relief groove that is approx. 1mm wide (approx. 0.2mm deep). ⑥ P dimensioned section (tapered area) is not ground. ⑦ The tip may have a centering hole. ⑧ $K \geq (S + 0.3)$
 $K = \sqrt{P^2 - W^2} \sin 30^\circ + W \cos 30^\circ$
 Reference: $\sin 30^\circ = 0.5$
 $\cos 30^\circ \approx 0.866$



Diamond Shape Configurable
Round Tip, Small Head

| Material | Hardness | ① Round Tip | | | | ② D-Shape Tip | | | | S | g6 |
|---------------------------|----------|-------------|-----------|----------|-----------|--------------------------------------|--------------------------------------|--------------------------------------|--------------------------------------|-------------|------------------|
| | | Type | | Type | | Type | | Type | | | |
| S45C Equivalent | - | KJPDTMV | KJPGDTMV | KJPDTV | KJPGDTV | S _{0.02} /F _{0.05} | S _{0.02} /F _{0.05} | S _{0.02} /F _{0.05} | S _{0.02} /F _{0.05} | 3.00 | -0.002 -0.008 |
| S45C Equivalent | 45HRC~ | KJPDTMVH | KJPGDTMVH | KJPDTVH | KJPGDTVH | - | - | - | - | 3.01~ 6.00 | -0.004 -0.012 |
| SUS304 | - | KJPDTMVS | KJPGDTMVS | KJPDTVVS | KJPGDTVVS | - | - | - | - | 6.01~10.00 | -0.005 -0.014 |
| SUS440C or 13Cr stainless | 45~50HRC | KJPDTMVC | KJPGDTMVC | KJPDTVVC | KJPGDTVVC | - | - | - | - | 10.01~18.00 | -0.008 -0.017 |
| | | | | | | | | | | 18.01~29.00 | -0.007 -0.020 |

D-Shape Tip, Small Head (Alteration ZC)

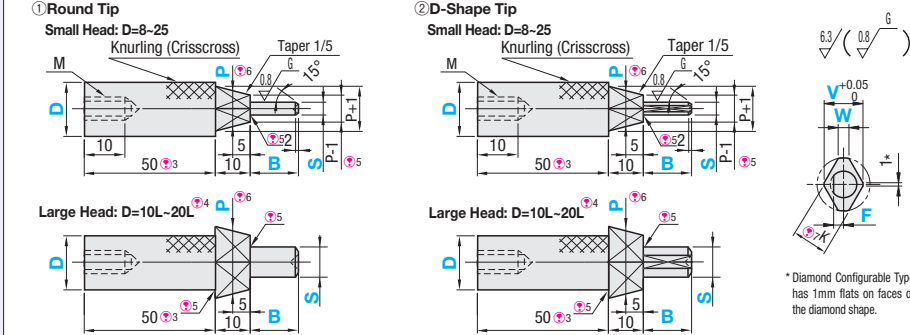

① Large Head Type (D=10L~20L) is available for S45C only. ② For electrolless nickel plating, specify the alteration MN. ③ For shorter handle length, specify the alteration ZC. ④ Dimensions not specified are the same as Small Head Type. ⑤ There is a relief groove that is approx. 1mm wide (approx. 0.2mm deep). ⑥ P dimensioned section (tapered area) is not ground. ⑦ $K \geq (S + 0.3)$
 $K = \frac{1W - V\sqrt{P^2 - W^2}}{\sqrt{P^2 + V^2 + 1 - 2\sqrt{P^2 - W^2} - 2VW}}$

*Diamond Configurable Type has 1mm flats on faces of the diamond shape.



| Part Number | ① Round Tip | | ② D-Shape Tip | | D | 0.01mm Increment | | | 0.1mm Increment | 1mm Increment | (W) | M |
|--------------------------------------|---------------------------------------|-------------------------------------|--------------------------------------|--------------------------------------|-------------|------------------|----------|-------------------|-----------------|---------------|-----|---|
| | S _{0.02} | S _{0.02} | S _{0.02} /F _{0.05} | S _{0.02} /F _{0.05} | | P | S(P-1±S) | F(F<S/2) | B | | | |
| (S45C) KJPDTKM | (S45C) KJPGDTKM | (S45C) KJPDTK | (S45C) KJPGDTK | 8 | 4.00~ 6.00 | 3.00~ 5.00 | 0.3~ 2.0 | 5~25 | 2 | M4 | | |
| (S45C Hardened) KJPDTKMH | (S45C Hardened) KJPGDTKMH | (S45C Hardened) KJPDTKH | (S45C Hardened) KJPGDTKH | 10 | 4.00~ 8.00 | 3.00~ 7.00 | 0.3~ 3.0 | | | | | |
| (SUS304) KJPDTKMS | (SUS304) KJPGDTKMS | (SUS304) KJPDTKS | (SUS304) KJPGDTKS | 12 | 6.00~10.00 | 3.00~ 9.00 | 0.3~ 4.0 | | | | | |
| (SUS440C or 13Cr stainless) KJPDTKMC | (SUS440C or 13Cr stainless) KJPGDTKMC | (SUS440C or 13Cr stainless) KJPDTKC | (SUS440C or 13Cr stainless) KJPGDTKC | 16 | 8.00~14.00 | 3.00~13.00 | 0.5~ 6.0 | | | | | |
| | | | | 20 | 12.00~18.00 | 5.00~17.00 | 1.0~ 8.0 | | | | | |
| | | | | 25 | 16.00~23.00 | 8.00~22.00 | 2.0~10.0 | | | | | |
| | | | | 10L | 10.00~16.00 | 5.00~15.00 | 1.0~ 7.0 | | | | | |
| | | | | 12L | 12.00~20.00 | 6.00~19.00 | 2.0~ 9.0 | | | | | |
| | | | | 16L | 16.00~25.00 | 8.00~24.00 | 2.0~11.0 | For SUS304, B≤Sx5 | 4 | M5 | | |
| | | | | 20L | 20.00~30.00 | 10.00~29.00 | 2.0~14.0 | | | | | |
| | | | | | | | | | | | | |
| | | | | | | | | | | | | |

① Large Head Type (D=10L~20L) is available for S45C only. ② Please select S dimension so that S section is smaller than the diamond section.

Ordering Example: Part Number (TYPE, D) - P - S - F - B
 KJPDTK12L - P16.00 - S8.00 - F2.2 - B10

| Part Number | ① Round Tip | | ② D-Shape Tip | | D | 0.01mm Increment | | | 0.1mm Increment | 1mm Increment | 0.1mm Increment | 0.5mm Increment | M |
|--------------------------------------|---------------------------------------|--------------------------------------|---------------------------------------|--------------------------------------|-------------|------------------|----------|----------|-----------------|---------------|-----------------|-------------------|----------|
| | S _{0.02} | S _{0.02} | S _{0.02} /F _{0.05} | S _{0.02} /F _{0.05} | | P | S(P-1±S) | F(F<S/2) | B | VP-V | W(V>W) | | |
| (S45C) KJPDTMV | (S45C) KJPGDTMV | (S45C) KJPDTV | (S45C) KJPGDTV | 8 | 4.00~6.00 | 3.00~4.00 | 0.3~2.0 | 5~25 | 4.0~5.0 | 1.0~4.5 | M4 | | |
| (S45C Hardened) KJPDTMVH | (S45C Hardened) KJPGDTMVH | (S45C Hardened) KJPDTVH | (S45C Hardened) KJPGDTVH | 10 | 4.00~8.00 | 3.00~6.00 | 0.3~3.0 | | | | | | |
| (SUS304) KJPDTMVS | (SUS304) KJPGDTMVS | (SUS304) KJPDTVVS | (SUS304) KJPGDTVVS | 12 | 6.00~10.00 | 3.00~8.00 | 0.3~4.0 | | | | | | |
| (SUS440C or 13Cr stainless) KJPDTMVC | (SUS440C or 13Cr stainless) KJPGDTMVC | (SUS440C or 13Cr stainless) KJPDTVVC | (SUS440C or 13Cr stainless) KJPGDTVVC | 16 | 8.00~14.00 | 4.00~12.00 | 0.5~6.0 | | | | | | |
| | | | | 20 | 10.00~18.00 | 5.00~16.00 | 1.0~8.0 | | | | | | |
| | | | | 25 | 15.00~23.00 | 8.00~21.00 | 2.0~10.0 | | | | | | |
| | | | | 10L | 10.00~16.00 | 5.00~14.00 | 1.0~7.0 | | | | | | |
| | | | | 12L | 12.00~20.00 | 6.00~18.00 | 2.0~9.0 | | | | | For SUS304, B≤Sx5 | 7.0~19.0 |
| | | | | 16L | 16.00~25.00 | 8.00~23.00 | 2.0~11.0 | | | | | | |
| | | | | 20L | 20.00~30.00 | 10.00~28.00 | 2.0~14.0 | | | | | | |
| | | | | | | | | | | | | | |

① Large Head Type (D=10L~20L) is available for S45C only. ② Please select V, W and S dimensions so that S dimension is smaller than the Diamond section.

Ordering Example: Part Number (TYPE, D) - P - S - F - B - V - W
 KJPDTMV16 - P10.20 - S6.80 - B20 - V8.0 - W6.0

| D | ① Round Tip Unit Price | | | | | | | | ② D-Shape Tip Unit Price | | | | | | | | | | | |
|------------|------------------------|-----|-----|-----|-------------------|----|-----|-----|--------------------------------------|-----|-----|-----|--------------------------------------|-----|----|----|-----|-----|-----|-----|
| | S _{0.02} | | | | S _{0.02} | | | | S _{0.02} /F _{0.05} | | | | S _{0.02} /F _{0.05} | | | | | | | |
| Small Head | 8 | 10 | 12 | 16 | 20 | 25 | 10L | 12L | 16L | 20L | 8 | 10 | 12 | 16 | 20 | 25 | 10L | 12L | 16L | 20L |
| Large Head | 10L | 12L | 16L | 20L | | | | | | | 10L | 12L | 16L | 20L | | | | | | |

Alterations: Part Number - P - S - F - B - (CH, KH-etc.)
 KJPDTK12 - P8.00 - S6.00 - F2.2 - B10 - CH
 KJPDTKMH16 - P8.00 - S5.00 - B15 - ZC20-KH

| Alterations | Code | Spec. |
|---|------|--|
| Additional Surface Treatment (Electroless Nickel Plating) | MN | Electroless nickel plating is applied. ① Applicable to Material S45C only. ② Combination with STC is not available. |
| Additional Surface Treatment (Black Oxide) | STC | Adds black oxide surface treatment. ① Applicable to Material S45C only. ② Combination with MN is not available. |
| Engraving of the Specified Characters | KF | Engraves alphabet or number. (Ordering Code) KF-MISUMI0034 Printable Character: alphabet, number, (period) ① Not applicable to handle length 10. ② No symbols, such as a hyphen (-), other than those mentioned above may be used for engraving. ③ The pin's orientation to the pin to be engraved characters is arbitrary. ④ Engraved on the reverse side when combined with KH. ⑤ Up to 8 digits max. ⑥ When combining with other options, enter this last. |
| Engraving of P Dimension | KH | Machines flats on knurled head and engraves P dimension (with the character orientation arbitrary). ① Not applicable to handle length 10. ② Engraved on the reverse side when combined with KF. |

| D | ① Round Tip Unit Price | | | | | | | | ② D-Shape Tip Unit Price | | | | | | | | | | | |
|------------|------------------------|-----|-----|-----|-------------------|----|-----|-----|--------------------------------------|-----|-----|-----|--------------------------------------|-----|----|----|-----|-----|-----|-----|
| | S _{0.02} | | | | S _{0.02} | | | | S _{0.02} /F _{0.05} | | | | S _{0.02} /F _{0.05} | | | | | | | |
| Small Head | 8 | 10 | 12 | 16 | 20 | 25 | 10L | 12L | 16L | 20L | 8 | 10 | 12 | 16 | 20 | 25 | 10L | 12L | 16L | 20L |
| Large Head | 10L | 12L | 16L | 20L | | | | | | | 10L | 12L | 16L | 20L | | | | | | |

Alterations: Part Number - P - S - F - B - V - W - (CH, KH-etc.)
 KJPDTMV16 - P10.20 - S6.80 - B20 - V8.0 - W6.0 - CH
 KJPDTV12 - P9.50 - S5.00 - F2.0 - B18 - V8.0 - W4.0 - ZC10

| Alterations | Code | Spec. |
|---|------|--|
| Additional Surface Treatment (Electroless Nickel Plating) | MN | Electroless nickel plating is applied. ① Applicable to Material S45C only. ② Combination with STC is not available. |
| Additional Surface Treatment (Black Oxide) | STC | Adds black oxide surface treatment. ① Applicable to Material S45C only. ② Combination with MN is not available. |
| Engraving of the Specified Characters | KF | Engraves alphabet or number. (Ordering Code) KF-MISUMI0034 Printable Character: alphabet, number, (period) ① Not applicable to handle length 10. ② No symbols, such as a hyphen (-), other than those mentioned above may be used for engraving. ③ The pin's orientation to the pin to be engraved characters is arbitrary. ④ Engraved on the reverse side when combined with KH. ⑤ Up to 8 digits max. ⑥ When combining with other options, enter this last. |
| Engraving of P Dimension | KH | Machines flats on knurled head and engraves P dimension (with the character orientation arbitrary). ① Not applicable to handle length 10. ② Engraved on the reverse side when combined with KF. |