

# Clamping Screws

Ball, Angle

# Clamping Screws / Hex Head Clamping Screws

Non-Reverse, Serrated

Tip / Head Clamp



Type		Main Body		Ball	
Ball	Angle	Material	Surface Treatment	Material	Hardness
HRSM	HFSM	SCM435 Equivalent	Black Oxide	SUJ2 Equivalent	55~60HRC
HRSU	HFSU	SUS304 Equivalent	-	SUS440C Equivalent	55~60HRC

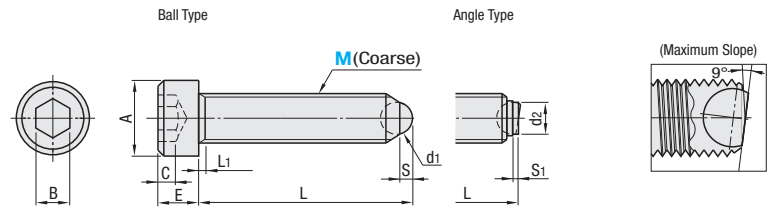

**Notes on Clamping Screws**  
 This product is used not to rotate face balls but to clamp workpieces. (The face balls do not necessarily rotate depending on each caulking conditions of face balls.)  
 For Angle Type, a sphere of its hemisphere appears on the face, instead of a flat plane by its rotation. In such a case, return its position using adhesive tape and magnet. Otherwise use Non-reverse Type to avoid rotations. **P.1736**

RoHS 10  Screw grade is judged whether or not it can be used with a commercially available nut which is JIS6H equivalent.



## Ball Type, Angle Type

Part Number Type	M	Nominal	L Selection		L1	A	E	B	C	d1	(d2)	S	S1	Allowable Load (kN)	Unit Price			
			HRSM	HFSM											HRSU	HFSU	HRSM	HRSU
(Ball) HRSM HRSU	4	10	10.5	10	2.1	7	4	3	2	2.5	2	0.8	0.3	1.3				
		12	12.5	12														
		16	16.5	16														
		20	20.5	20														
		25	25.5	25														
(Ball) HRSU	5	12	12.6	12	2.4	8.5	5	4	2.5	3	2.5	1	0.4	1.4				
		16	16.6	16														
		20	20.6	20														
		25	25.6	25														
(Angle) HFSM HFSU	6	16	16.8	16	3	10	6	5	3	4	3.2	1.3	0.5	3.3				
		20	20.8	20														
		25	25.8	25														
		30	30.8	30														
		40	40.8	40														
(Angle) HFSM HFSU	8	20	21.2	20	3.5	13	8	6	4	5.5	4.5	1.8	0.6	3.9				
		30	31.2	30														
		40	41.2	40														
		50	51.2	50														
		60	61.2	60														
(Angle) HFSM HFSU	10	25	26.7	25	4.5	16	10	8	5	7	6	2.3	0.6	3.4				
		30	31.7	30														
		40	41.7	40														
		50	51.7	50														
(Angle) HFSM HFSU	12	30	32	30	5	18	12	10	6	8.5	7.2	2.8	0.8	4.8				
		40	43.3	40														
		60	63.3	60														
		80	83.3	80														
(Angle) HFSM HFSU	16	40	43.3	40	6	24	16	14	8	12	10.7	4.3	1.0	9.6				
		80	83.3	80														

kgf=Nx0.101972

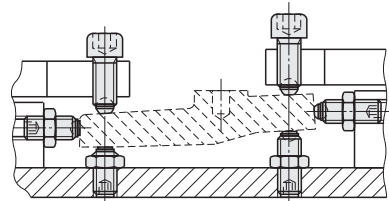

Ordering Example Part Number **HRSM6-16**

Type		Main Body		Ball	
Non-Reverse	Non-Reverse Serrated	Material	Surface Treatment	Material	Hardness
HFMB	HFMG	SCM435 Equivalent	Black Oxide	SUJ2 Equivalent	55~60HRC
HFUB	-	SUS304 Equivalent	-	SUS440C Equivalent	55~60HRC

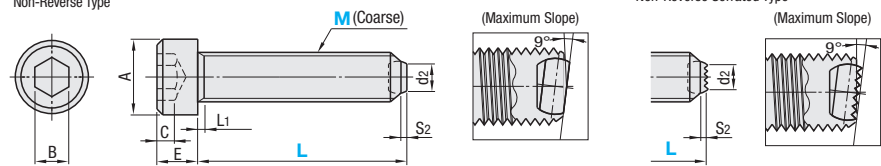

RoHS 10  Screw grade is judged whether or not it can be used with a commercially available nut which is JIS6H equivalent.

Part Number Type	M	L Selection								L1	A	E	B	C	d2	S2	Withstand Load (kN)	Unit Price			
		6	8	10	12	16	20	25	30									35	40	45	50
(Non-Reverse) HFMB HFUB (Non-Reverse Serrated) HFMG	6	16	20	25	30	40					3	10	6	5	3	3.2	0.45	3.3			
		8	20	30	35	40	50				3.5	13	8	6	4	4.5	0.5	3.9			
		10	25	30	40	50	60				4.5	16	10	8	5	6	0.6	3.4			
		12	30	40	50	60	80				5	18	12	10	6	7.2	0.75	4.8			
		16	40	60	80						6	24	16	14	8	10.7	1	9.6			

kgf=Nx0.101972

Ordering Example Part Number **HFMB10** - **L** **30**



Type		Main Body			Ball	
Ball	Angle	Material	Hardness	Surface Treatment	Material	Hardness
BRASM	BFASM	SCM435	32~40HRC	Black Oxide	SUJ2	62HRC~

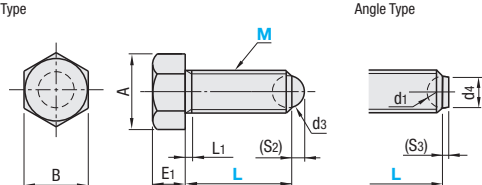

RoHS 10  **Notes on Clamping Screws**  
 This product is used not to rotate face balls but to clamp workpieces. (The face balls do not necessarily rotate depending on each caulking conditions of face balls.)  
 For Angle Type, a sphere of its hemisphere appears on the face, instead of a flat plane by its rotation. In such a case, return its position using adhesive tape and magnet.

Part Number Type	M	L Selection								L1	A	B	E1	d1	d3	d4	(S2)	(S3)	Unit Price	
		6	8	10	12	16	20	25	30										35	40
BRASM BFASM	6	20	30	40						2	11.5	10	4	5.6	4	3.2	1.3	0.6		
		8	20	30	40					2.5	15	13	5.5	8	5.5	4.5	1.8	0.8		
		10	40	50						3	19.6	17	7	9.5	7.1	6	2.3	0.9		
		12	50	60						3.5	21.9	19	8	12.7	8.7	7.2	2.8	1		
		16	50	60						4	27.7	24	10	15.9	11.9	10.7	4.3	1.3		

Ordering Example Part Number **BFASM6** - **L** **20**



Type		Main Body			Ball	
Ball	Angle	Material	Hardness	Surface Treatment	Material	Hardness
BRSM	BFSM	SCM435	32~40HRC	Black Oxide	SUJ2	62HRC~
BRSMS	-	SUS304	-	-	SUS440C	55HRC~

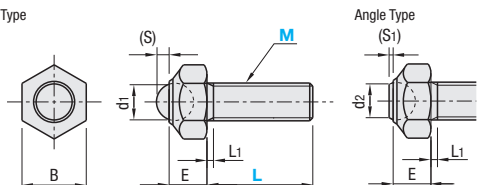

RoHS 10  **Notes on Clamping Screws**  
 This product is used not to rotate face balls but to clamp workpieces. (The face balls do not necessarily rotate depending on each caulking conditions of face balls.)  
 For Angle Type, a sphere of its hemisphere appears on the face, instead of a flat plane by its rotation. In such a case, return its position using adhesive tape and magnet.

Part Number Type	M	L Selection								L1	B	E	d1	d2	(S)	(S1)	Unit Price		
		6	8	10	12	16	20	25	30								35	40	45
BRSM BRSMS BFSM	6	30	40							2	10	6	5.6	4.5	2	0.8			
		8	30	40						2.5	13	8	8	6.7	2.8	1			
		10	40	50						3	17	10	9.5	7.9	3.2	1.2			
		12	50	60						3.5	19	12	12.7	10.8	4.7	1.8			
		16	50	60						4	24	16	15.9	13.3	5.7	2.1			

Ordering Example Part Number **BFSM12** - **L** **50**