

Pulley Holders for Conveyor - Bearing Type

Dedicated web site <http://fa.misumi.jp/cvs/>
 Conveyor selecting, component purchases, and easy search for maintenance parts are available.

Pulley Holders for Conveyor - Tension Type

Dedicated web site <http://fa.misumi.jp/cvs/>
 Conveyor selecting, component purchases, and easy search for maintenance parts are available.



MMaterial Aluminum
SSurface Treatment Paint

PLHDB-FC-R

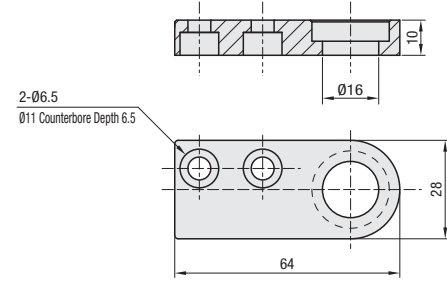

PLHDB-FD-R

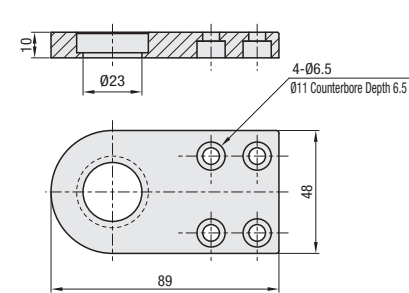

PLHDB-FE

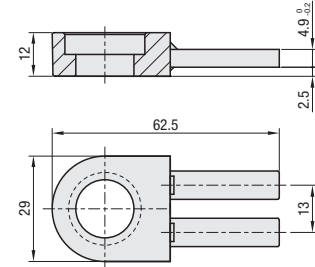

PLHDB-FER-R

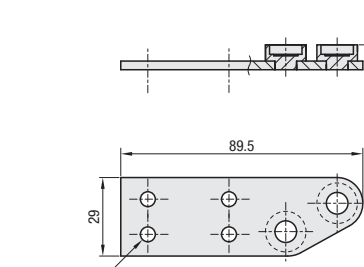

PLHDB-FF-R

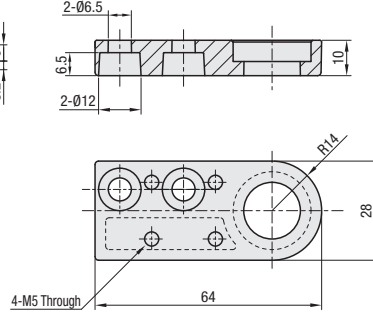

PLHDB-FG-R

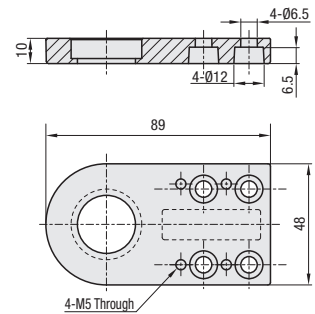

PLHDB-TC-R

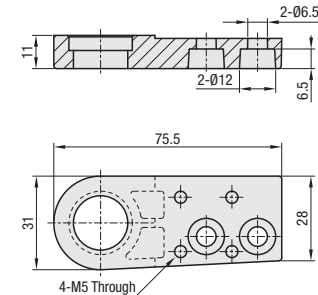

PLHDB-TD-R

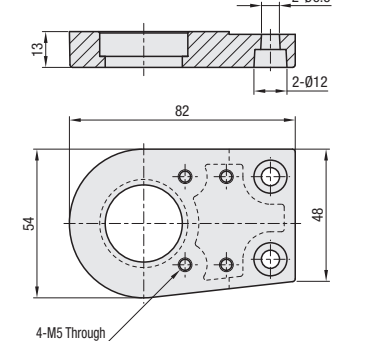

Ⓜ Drawing with trailing L is reversed type of R.
 Ⓜ For detail dimensions, see the e-Catalog.
 Ⓜ Bearings are not included. Please specify in alterations if needed.

Part Number	Shape Selection	Right/Left	Bearing							Applicable Conveyors	Unit Price	
			Bearing No.	d	D	B	Ds min.	Ds max.	dh max.			R max.
PLHDB	FC	(Right) R	B6900ZZ	10	22	6	12	13	20	0.3	CVSFA	
		(Left) L	B6001ZZ	12	28	8	14	16	26	0.3	CVSFC	
	FD	(Right) R	B6900ZZ	10	22	6	12	13	20	0.3	CVSFB	
		(Left) L	B6001ZZ	12	28	8	14	16	26	0.3	CVSFD	
	FE	(Right) R	B6900ZZ	10	22	6	12	13	20	0.3	CVSSA	
		(Left) L	B6001ZZ	12	28	8	14	16	26	0.3	SVKA	
	FER	(Right) R	B6900ZZ	10	22	6	12	13	20	0.3	SVKB	
		(Left) L	B6001ZZ	12	28	8	14	16	26	0.3	SVKN	
	FF	(Right) R	B6900ZZ	10	22	6	12	13	20	0.3	SVKR	
		(Left) L	B6001ZZ	12	28	8	14	16	26	0.3	SVKN	
	FG	(Right) R	B6900ZZ	10	22	6	12	13	20	0.3	CVGA	
		(Left) L	B6001ZZ	12	28	8	14	16	26	0.3	CVGB	
TC	(Right) R	B6801ZZ	12	21	5	14	14.5	19	0.3	CVGP		
	(Left) L	B6002ZZ	15	32	9	17	19	30	0.3	CVGN		
TD	(Right) R	B6801ZZ	12	21	5	14	14.5	19	0.3	CVGC		
	(Left) L	B6002ZZ	15	32	9	17	19	30	0.3	CVGD		

Ordering Example
 Part Number - Shape Selection - Right/Left
PLHDB - FC - L

Alterations
 Part Number - Shape Selection - Right/Left - (BR)
PLHDB - FC - L - BR

Alterations	Code	Spec
Bearing Set	BR	Bearing is attached to the pulley holder. Ordering Code BR



MMaterial Aluminum
SSurface Treatment Paint

PLHDT-FE

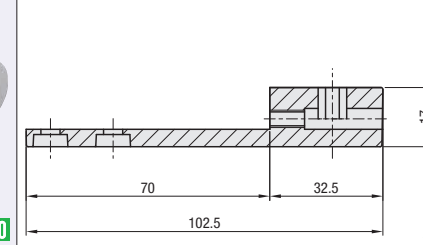

PLHDT-FJ-R

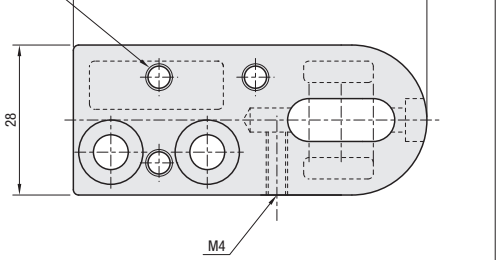
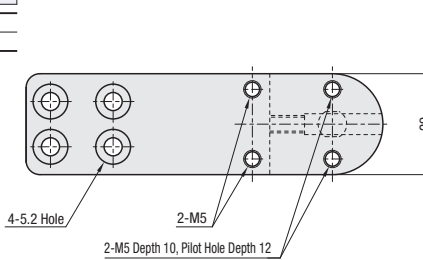
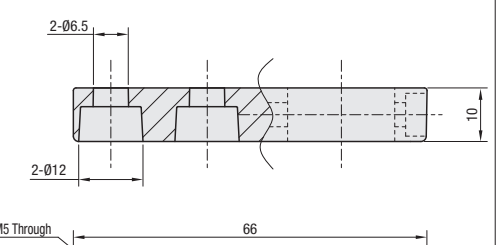

PLHDT-FK-R

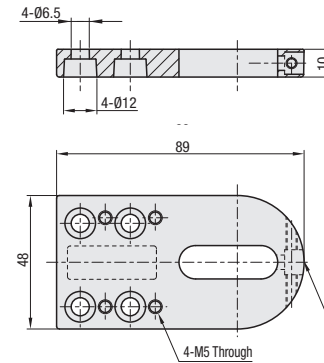

PLHDT-TC-R

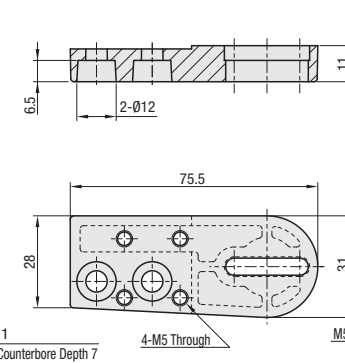

PLHDT-TD-R

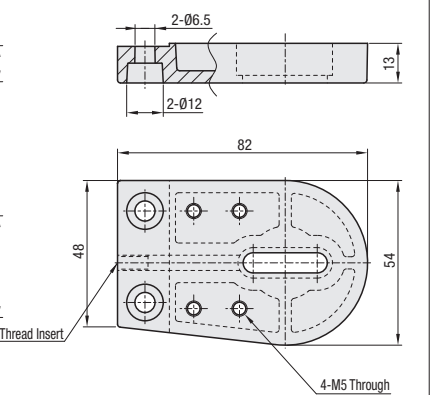

Ⓜ Drawing with trailing L is reversed type of R.
 Ⓜ For detail dimensions, see the e-Catalog.

Part Number	Shape Selection	Right/Left	Tension Bolt Part Number	Applicable Conveyors	Unit Price
PLHDT	FE	-	FABBS5-45	SVKA	
		-	SCB4-28	SVKB	
	FJ	(Right) R	SCB4-28	CVGA	
		(Left) L	SCB4-28	CVGB	
	FK	(Right) R	ACB5-35	CVGP	
		(Left) L	ACB5-35	CVGN	
	TC	(Right) R	-	CVGC	
		(Left) L	-	CVGD	
	TD	(Right) R	-	CVGR	
		(Left) L	-	CVGW	
	TD	(Right) R	-	CVGTA	
		(Left) L	-	CVGTB	

Ordering Example
 Part Number - Shape Selection - Right/Left
PLHDT - FJ - L

Alterations
 Part Number - Shape Selection - Right/Left - (TB)
PLHDT - FJ - L - TB

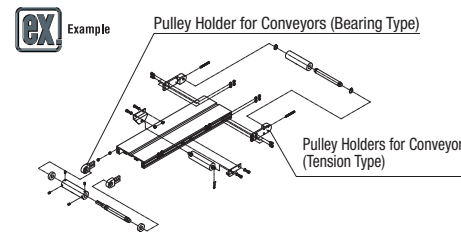

Alterations	Code	Spec
Tension Bolt Set	TB	Tension bolt is attached to the pulley holder Ordering Code TB